



Available with modular hanging screen system.



Featuring Sandvik's unique C1621 Prisec impact chamber (5 patents pending). The Prisec concept enables one base crusher to be configured as either a Primary or Secondary chamber whilst maintaining optimum crushing geometry.

Diagram illustrates the curtain pivot shafts in upper position for primary applications.

Diagram illustrates the curtain pivot shafts in lower position for secondary applications.

- 1 Lifting jib and hammer cradle supplied as standard for quick and easy maintenance.
- 2 Heavy duty fully welded chamber enclosure to withstand the toughest of applications.

- 1 Chamber lined with interchangeable abrasion resistant tiles which can be turned for maximum usage.
- 2 Curtain V block brake adjustment and overload system for maximum protection.

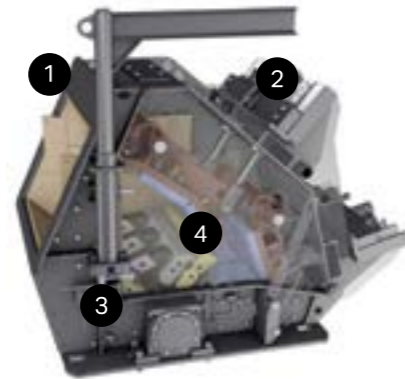
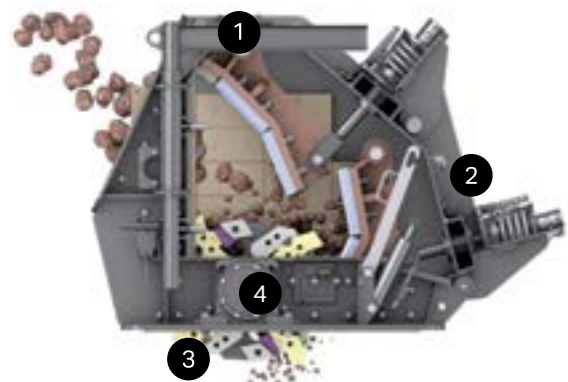

- 3 Heavy duty 4 hammer rotor with interchangeable hammer configuration.
- 4 Heavy duty oversized spherical roller bearings for maximum strength and durability.

- 3 Wedge locking for simple hammer retention.
- 4 2 Heavy duty curtains lined with abrasion resistant Sandvik liners.

New patented rotor position and locking device for increased safety.  
New hammer locking wedges for quicker removal and fitting.  
New wedge removal tool for safer installation and removal.



### TECHNICAL SPECIFICATIONS

KEY SPECIFICATIONS	QI442
Primary feeder	
Wear resistant lined feeder	1274 mm x 2395 mm / 4' 2" x 7' 10"
Pre screen	
Wear resistant top deck grizzly / punch plate	1360 mm x 2160 mm / 4' 6" x 7' 1"
Bottom deck mesh	1360 mm x 1730 mm / 4' 6" x 5' 8"
Pre screen top deck media	40 mm / 1 1/2" punch plate
Pre screen bottom deck media	20 mm / 3/4" mesh
Underpan feeder size	1022 mm x 2400 mm / 40" x 94"

KEY SPECIFICATIONS	QI442
Impactor	Sandvik C1621 Prisec
Feed opening	1360 mm x 800 mm / 54" x 32"
Hydraulic inlet opening	1360 mm x 1000 mm / 54" x 39"
2 aprons	Hydraulic assist
Maximum feed size	800 mm / 32"
Engine	CAT C13 & C13B Stage 5 / T4F 340 kW / 456 hp T4F 328 kW / 440 hp Tier 3 261 kW / 350 hp
Drive type	Direct wet clutch drive
Fuel tank	660 litres / 174 USG
Hydraulic tank	660 litres / 174 USG

Note. All weights and dimensions are for standard units only

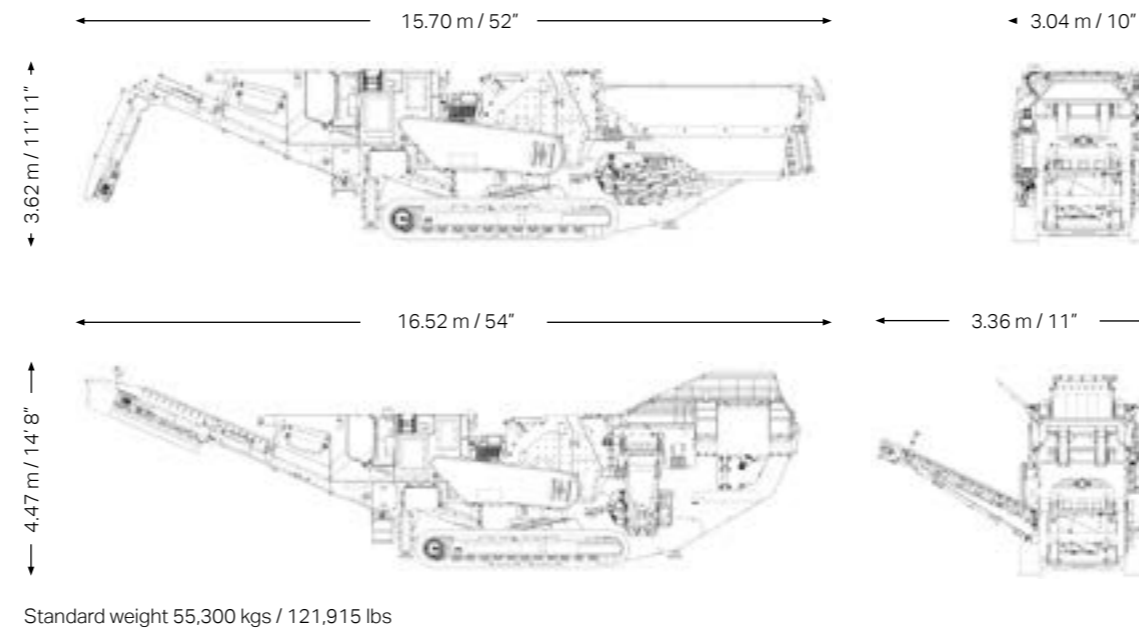

BB-489 ENG © Sandvik Mining and Rock Technology 2020 SANDVIK is a registered trademark owned by Sandvik Intellectual Property AB in Sweden and other countries. Subject to change without notice.



# SANDVIK QI442 HSI IMPACTOR



# QI442 HSI IMPACTOR

KEY SPECIFICATIONS	DATA
Equipment	Sandvik CI621 Prisec Impactor
Feed opening	1360 mm x 800 mm / 54" x 32"
Maximum feed size	800 mm / 32"
Engine	CAT C13 & C13B Stage 5 / T4F 340 kW / 456 hp T4F 328 kW / 440 hp Tier 3 261 kW / 350 hp
Transport dimensions	15,700 m / 52" (l) 3040 m / 10" (w) 3620 m / 11' 11" (h)
Weight	55,300 kgs / 121,915 lbs

## HIGH THROUGHPUT

Featuring Sandvik's market leading technology, the QI442 Horizontal Shaft Impactor will offer customers unparalleled flexibility in primary and secondary applications, undoubtedly proving to be the perfect solution for large scale operators.

Its heavy duty chassis has been designed for ease of mobility and yet is able to withstand the toughest of environments. It incorporates the Sandvik CI621 Prisec impact crusher which is suitable for a wide variety of applications in demolition, recycling and quarrying.

It is available with an optional double deck hanging screen system, which will allow customers an even greater return on investment through the facility to produce accurately sized products for immediate use.

## FEATURES INCLUDE:

- Excellent reduction ratio across a broad spectrum
- Designed for optimum fuel economy and low operating costs
- Direct drive through hydraulic wet clutch
- Overband magnet, pre screen and underpan feeder fitted as standard
- Choice of pre screen media which provides the flexibility to suit any application
- 50°C ambient temperature capability without the need for an oil change

## STANDARD FEATURES



Hydraulic raise and lower on the main conveyor



Easy access to the engine compartment



User friendly PLC control system with colour screen



Double deck vibrating pre screen



Vibrating primary feeder



Patented rotor locking and positioning device for increased safety

**1 Main conveyor**

- 1200 mm / 47" wide conveyor with a discharge height of 4074 mm / 13' 4" and dual hydraulic drive
- Hydraulic raise / lower facility to give increased clearance for rebar discharge in recycling applications
- Overband magnet removes rebar for recycling and demolition applications
- Dust suppression spray bars fitted as standard
- Highly efficient belt scraper

**2 Cooling fan**

- Hydraulically driven cooling fan with auto reverse to back flush dust from radiator

**3 Power pack**

- Emissions compliant engine
- Direct drive through wet hydraulic clutch
- Easy access to engine compartment for service and maintenance
- Ground level drainage points
- Large capacity 660 litre / 174 USG diesel tank
- Lighting mast and cabinet lights
- My Fleet telematics

**4 Impactor box**

- Sandvik CI621 - Patented design to work in either a primary or secondary application
- Feed opening 1360 x 800 mm / 54 x 32"
- 4 hammer rotor - 1150 mm / 45" diameter
- Ceramic hammers fitted as standard
- Variable speed of 563 rpm to 696 rpm
- Tip speed range of 34 to 42 m/s / 112 to 138 ft/s to achieve a wide range of product gradations
- Inlet opening can be raised to clear blockages from the radio remote

**5 Pre screen**

- Heavy duty double deck pre screen
- Choice of media
- 3 position by-pass chute for ultimate separation
- Fitted with a pre-screen to ensure maximum scalping capability to increase throughput and reduce wear cost

**6 Hopper**

- Reinforced hopper with hydraulically folding doors

**7 Primary feeder**

- Large capacity spring mounted vibrating feeder
- Wear resistant liner plates fitted as standard
- Engine load monitoring regulates the feeder speed to reduce blockages and wear

**8 Natural fines conveyor**

- Fitted for removal of fines
- Belt width 650 mm / 26"
- Discharge height 3084 mm / 10' 1"

**9 Underpan feeder**

- Fitted as standard for maximum belt protection and to reduce spillage

**10 Steel pipework (other side of machine)**

- Provides a safe and maintenance-free sealing solution, combined with better heat dissipation

**11 Tracks**

- 500 mm / 20" wide tracks driven by proportional umbilical control
- Radio remote control, proportional tracking as standard

**12 Control system (other side of the machine)**

- Highly efficient hydraulic and electric system provides ultimate system control
- User friendly PLC control system with colour screen for full automated control

**13 Chassis**

- Heavy duty fabricated chassis on tracked frame
- Hydraulic legs for increased stability and servicing capabilities

**14 Hanging screen system (optional)**

- 4 x 1.5 m / 13' x 5' double deck screen for recirculation back to feed conveyor, or stockpiling through 90° rotation of oversize conveyor to produce two products
- Fully detachable screen for flexible operation
- Multi-functional and quick conversion from open to closed circuit in 30 minutes
- Flexibility to change from double to single deck
- Extended conveyor fitted as standard with HS option