



### TECHNICAL SPECIFICATIONS

KEY SPECIFICATIONS	DATA
Screen type	2 off screenboxes, 2 Bearing 3 Deck
Screen box size	20' x 5' / 6 x 1.5 m
Tensioning system	Manual Ratchet
Speed	1200 rpm
Throw	7.7 mm
Motor	49 cc x 2 off

KEY SPECIFICATIONS	DATA
Power pack	
Engine	CAT C4.4 74.5 kw / 100 hp
Diesel tank size	290 litres / 76.5 USG
Hydraulic tank size	370 litres / 98 USG

Note. All weights and dimensions are for standard units only

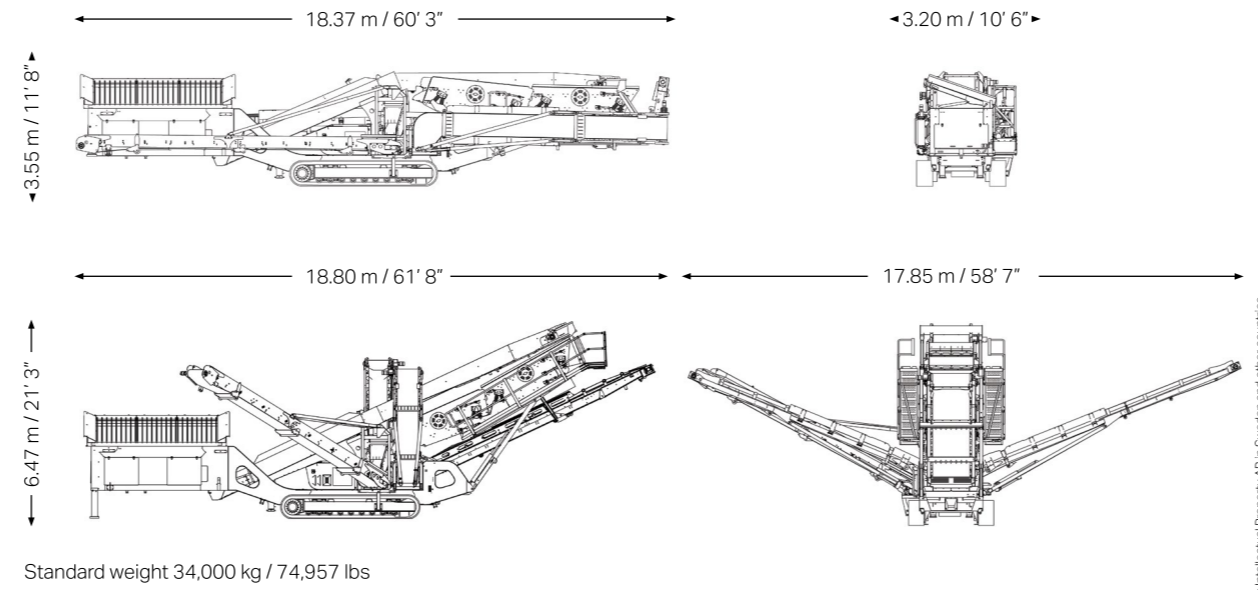

At the heart of the QA451 is the Triple deck Doublescreen box, featuring two independent triple deck screen boxes. Both feature independent drives and can have their amplitudes and combined screen angles adjusted dependant upon application. The QA451 offers a screening solution no other mobile triple deck screener can provide as its two screen boxes offer an unsurpassed level of separation on a wide range of materials, at very high rates of production.

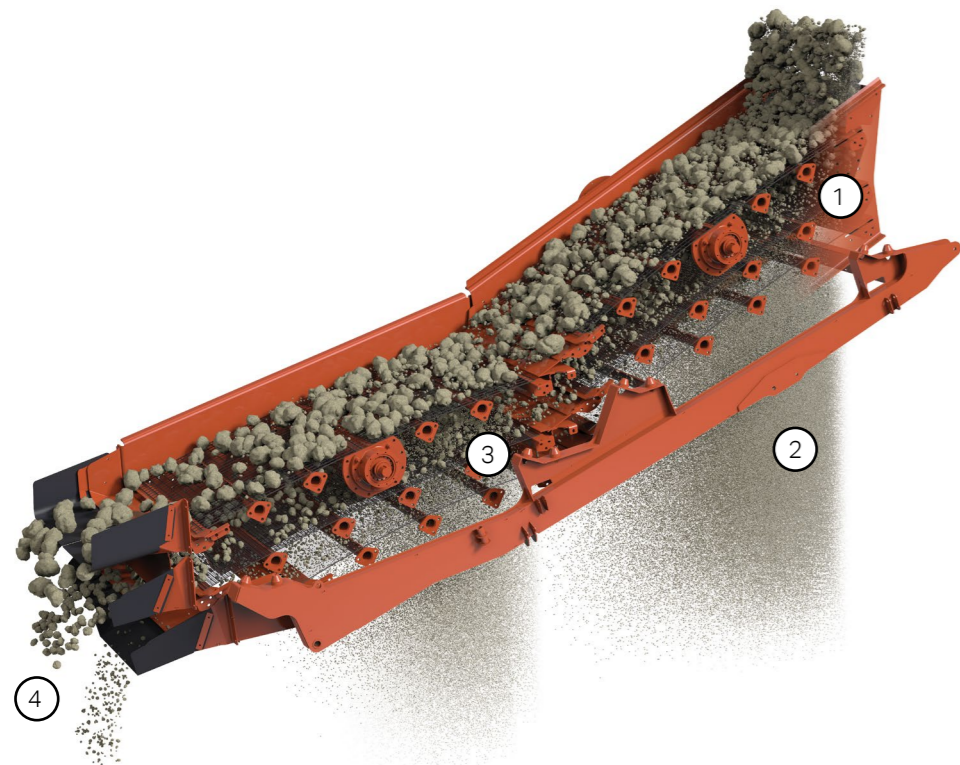

- ① First screen box is used as a fines extractor
- ② The majority of the undersize is removed during initial impact
- ③ Second screen box operates as a grader
- ④ Clean gradings, at very high output, are produced as material is exposed to a very large screening area

# QA451 DOUBLESREEN ENGINEERING IN MOTION

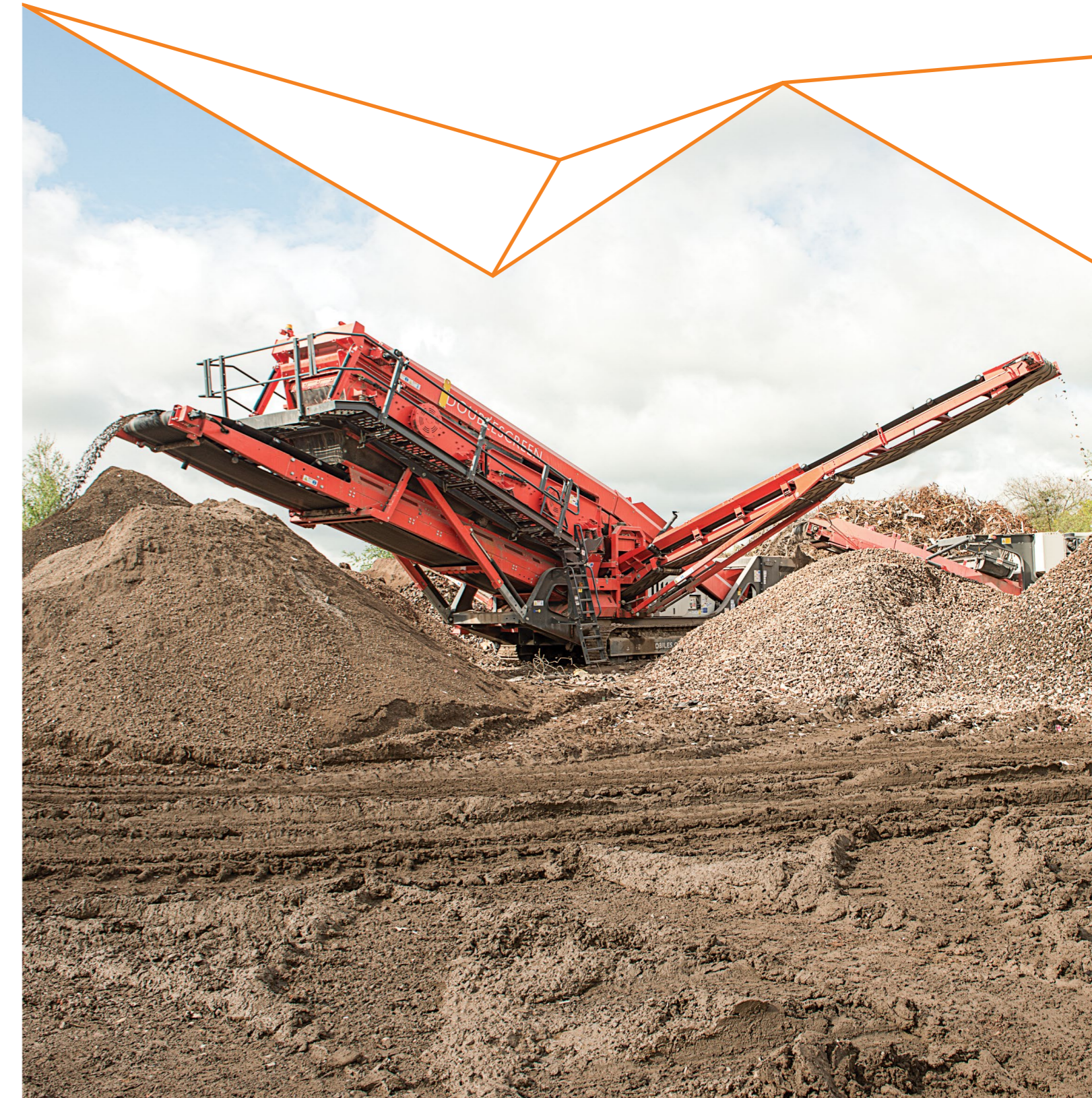

# QA451 TRIPLE DECK DOUBLESCREEN ENGINEERING IN MOTION

KEY SPECIFICATIONS	DATA
Screen type	Sandvik Doublescreen 3-deck
Screen box size	20' x 5' / 6 x 1.5 m
Engine	C4.4 74.5 kW / 100 hp
Transport dimensions	18.37 m / 60' 3" (l) 3.20 m / 10' 6" (w) 3.55 m / 11' 8" (h)
Weight	34,000 kg / 74,957 lbs

## ULTIMATE SCREENING SOLUTION

The QA451 is the largest and most impressive mobile tracked screener in the Premium range and the only screener in the world with a triple decked Doublescreen screening system. Building upon the success of the QA450, the QA451 represents the next generation model with numerous product enhancements to produce a more user-friendly, efficient and productive unit.

The QA451 is designed specifically to work in closed circuit with our tracked secondary and tertiary crushers. The hydraulically folding fourth product conveyor slews and raises/lowers hydraulically to optimise the feeding position to these upstream units. Alternatively, the QA451 can work as an extra-large stand-alone screening and stockpiling system producing four sized products with a fifth oversize material scalped off at the grid.

## FEATURES INCLUDE:

- High production capabilities due to its phenomenal Doublescreen system - two in-line, independently vibrating 10' x 5' / 3 x 1.5 m triple deck screenboxes
- Four on-board hydraulic folding stockpilers
- Enlarged oversize conveyor chute prevents bottle necks and ensures free flow of material.
- Large volume hopper complete with remote control hydraulic tipping grid
- Fully compliant with the latest safety regulations
- Capable of working in the most hostile of environments
- Designed for optimum fuel economy and low operating costs.

**1 Mids-fines side conveyor**

- 700 mm / 27.5" wide belt with a discharge height of 4915 mm / 16' 9" for enormous stockpiling capability
- Hydraulically folds forwards alongside screenbox and walkway for ease of transport

**2 Mid-overs side conveyor (other side of machine)**

- 700 mm / 27.5" wide belt with a discharge height of 5130 mm / 16' 10" for massive stockpiling capability

**3 Screen box**

- Triple deck 20' x 5' / 6 x 1.5 m equivalent patented Doublescreen for high production capabilities
- Easy-change mesh facility with highly efficient ratchet tensioning system
- Hydraulically folding walkways for ease of maintenance

**4 Main conveyor**

- 1000 mm / 39" wide variable speed feed conveyor
- Can be hydraulically raised up from screenbox to enable quick mesh change and easy maintenance

**5 Fines tail conveyor**

- 1200 mm / 47" wide belt with a discharge height of 5030 mm / 16' 6" for massive stockpiling capability

**6 Chassis**

- Modern chassis design on tracked frame ensures maximum durability
- Hydraulic legs for increased stability and servicing capabilities

**7 Tracks**

- 500 mm / 19.5" wide tracks driven by radio control as standard for ultimate maneuverability on site

**8 Power pack**

- Diesel driven 74.5 kW / 100 hp emissions compliant engine
- User friendly push button control panel with sequential start-up for ease of operation
- Easy access to the engine compartment for service and maintenance

**9 Hopper**

- Large volume hopper complete with remote control hydraulic tipping grid
- Vibrating grid available as an option
- Variable speed belt feeder, heavy duty-roller bed and heavy duty belting
- Heavy duty feeder drive system for increased throughput

**10 Oversize conveyor**

- Hydraulic raise / lower and hydraulic slew function for quicker set-up times, stockpile clearing and recirculating with secondary and tertiary crushers
- 650 mm / 25" 5" wide belt for maximum oversize material removal
- Discharge height 4897 mm / 16' 1" for enormous stockpiling capability
- Compatible with optional vibrating grid

## STANDARD FEATURES



Hydraulic slew and raise / lower facility



Remote control for ease of mobility



Patented triple deck Doublescreen technology



Colour coded control panel for ease of operation



Hydraulically folding walkways for ease of maintenance



Massive stockpiling capabilities